

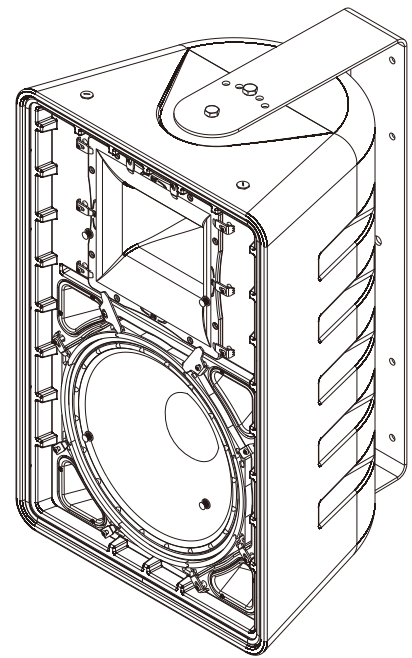

ONE SYSTEMS[®]
ACOUSTIC EXCELLENCE[®]

ONE.SL15



OVERVIEW:

The One Systems ONE.SL15 is a weather protected, direct-radiating 15-inch two-way loudspeaker solution for professional audio applications indoors or for inland uses outdoors. The system's direct-radiating transducers include a 15-inch woofer with a 3-inch voice coil and a compression driver with a 2.5-inch pure titanium diaphragm coupled to a large rotatable 60° x 40° horn. Its one-piece rotomolded enclosure is made of UV resistant High-Density Polyethylene (HDPE) with internal steel reinforcements for added strength. The enclosure is ported to enhance its low frequency performance. The ONE.SL15's input section features an input weather cover with an IP 68-rated gland nut and its barrier strip has stainless steel hardware. The enclosure has 10 x M10 integrated stainless steel rigging points, which can be used in conjunction with the included U-Bracket for mounting to walls or ceilings. An optional pole mount bracket is also available for additional installation flexibility.

PERFORMANCE:

The ONE.SL15 provides high vocal intelligibility with wide response capability from its reasonably-sized enclosure. Its compression driver with pure titanium diaphragm delivers extended response and its long-throw horn is rotatable to facilitate horizontal or vertical placement for added flexibility. The woofer's specially treated cone and surround provide excellent acoustic damping, moisture resistance and protection against dry rotting. The ONE.SL15's vented enclosure and premium components provide 126 dB continuous, 132 dB peak output capability with wide frequency response and excellent transients for precise

FEATURES AND BENEFITS

- High-performance 15-inch two-way speaker that provides high intelligibility and musical fidelity with solid low end capability from a reasonably-sized enclosure
- 500 watts continuous, 2,000 watts peak power handling
- 60° x 40° rotatable long-throw horn
- Includes robust structural steel U-Bracket with dual-layer, zinc-rich powder coating
- 3-stage "Rain Shield" grille
- 10 x M10 Stainless steel rigging points provide long-term safety and high corrosion resistance
- IP 55 direct weather rating permits use for inland outdoor applications
- Input weather cover with IP 68-rated gland nut
- Optional SL.PMT pole mount kit available

One Systems, Inc.

www.onesystems.com

tel: +1-615-823-1655

fax: +1-615-261-1429

ONE.SL15 SPECIFICATIONS

Frequency Response: 50 - 18,000 Hz \pm 3 dB
Frequency Range: 40 - 20,000 Hz -10 dB
Power Handling: 500 watts continuous
 1,000 watts program
 2,000 watts peak *

NOTE: All system power handling ratings are amplifier headroom dependent

Sensitivity (1 watt @1 meter): 100 dB
Calculated Output Capability: 126 dB continuous
 132 dB peak
Coverage (H x V): Rotatable 60° x 40°
Nominal Impedance: 8 ohms

Input Connection: Barrier strip
LF Transducer: 15 in / 381 mm with 3 in voice coil
HF Transducer: 2.5 in / 63 mm with titanium diaphragm
Dimensions (H x W x D), mm: 779.7 x 513.2 x 422.2 mm
Dimensions (H x W x D), in: 30.7 x 20.2 x 16.6 in
Net Weight: 35 kg / 77.2 lb
Direct Weather Performance: IEC 60529 / IP 55
Finish: Gray
Recommended High-Pass: 50 Hz, 24 dB Butterworth
Optional Accessories:
Pole Mount Bracket: SL.PMT
EASE Data: www.onesystems.com/ease-data

DIRECT-WEATHER FEATURES

- * Rotomolded enclosure is made of High-Density Polyethylene (HDPE) resin with steel reinforcements that provides very high UV, moisture and temperature resistance
- * All rigging hardware is made of stainless steel for long-term safety and high corrosion resistance
- * Three-layer "rain shield" grilles are made of structural steel with a marine-capable powder coating that permits use for inland outdoor applications more than 16 km / 10 miles from oceans or salt air
- * The system is rated IEC 60529 Standard / IP 55 (protected against water spray from any direction; protected from limited dust ingress)
- * Input weather cover with an IP 68-rated gland nut prevents moisture intrusion
- * Advanced transducer's specially-treated cone and surround are specially treated to handle moisture, temperature and humidity extremes while delivering premium audio performance

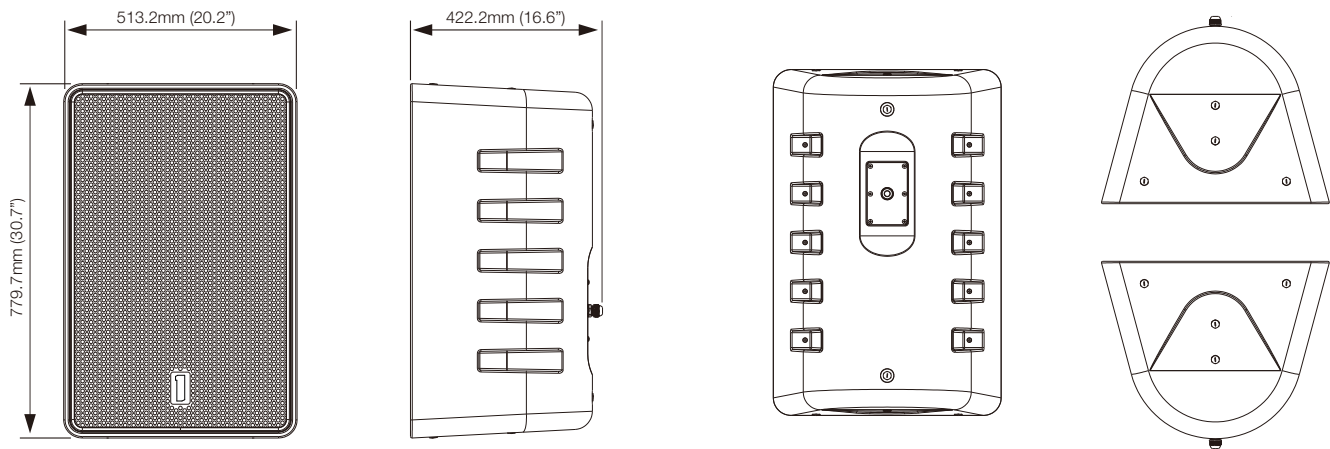

The ONE.SL15 must be installed with a minimum 5-degree down-tilt. If mounted vertically, the logo should be positioned at the bottom of the speaker

